

**REFERENCE IMAGES FOR OTR ARRANGEMENTS**



**Picture 1 – Ship's Brow (Length - 40 feet with roller on both ends)**



**Picture 2 – Yokohoma Fender (Approx Diameter – 6.5 m)**



**Picture 3 – Fresh Water Coupling: Female End**

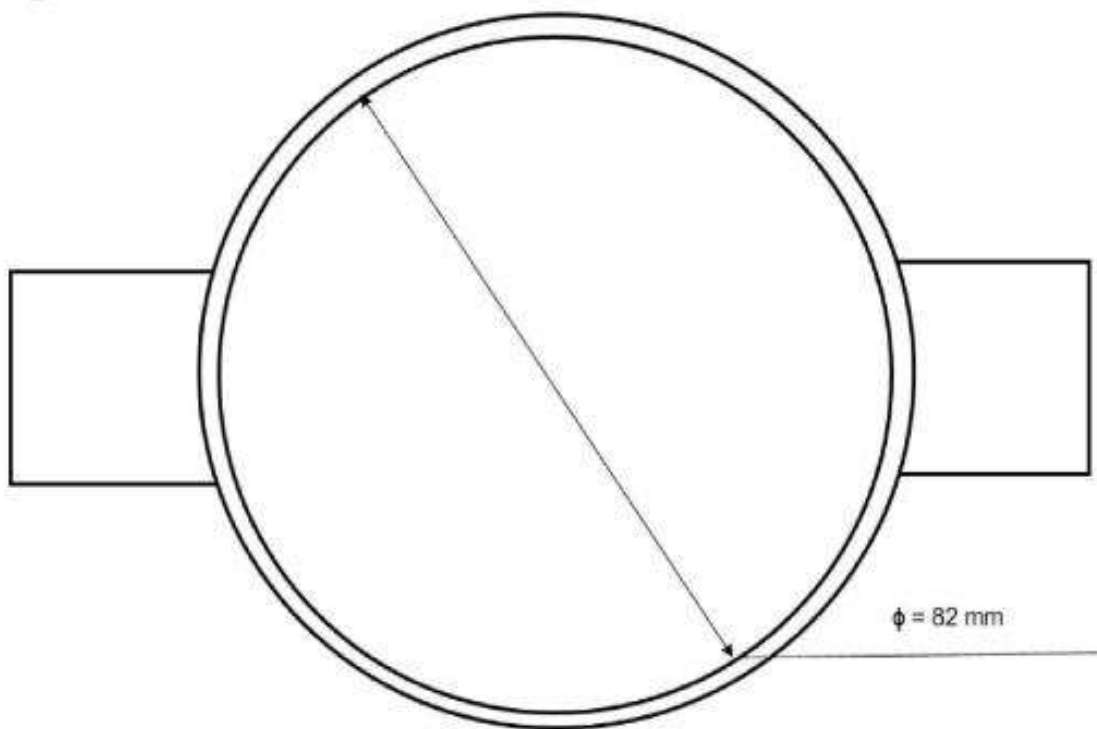

**Picture 4 – Fresh Water Coupling: Female End Dimensions**

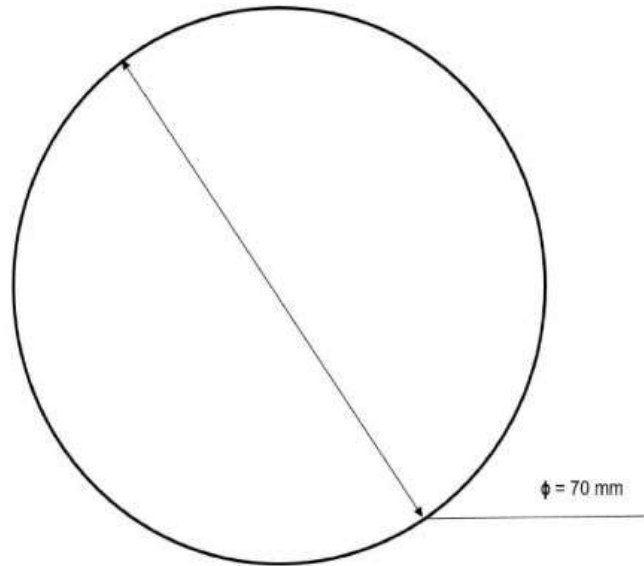

**Picture 5 – Fresh Water Coupling Male End – Image and Dimensions**



**Picture 6 – Fuel Coupling (Type A): Front View (Left) and Side View (Right)**



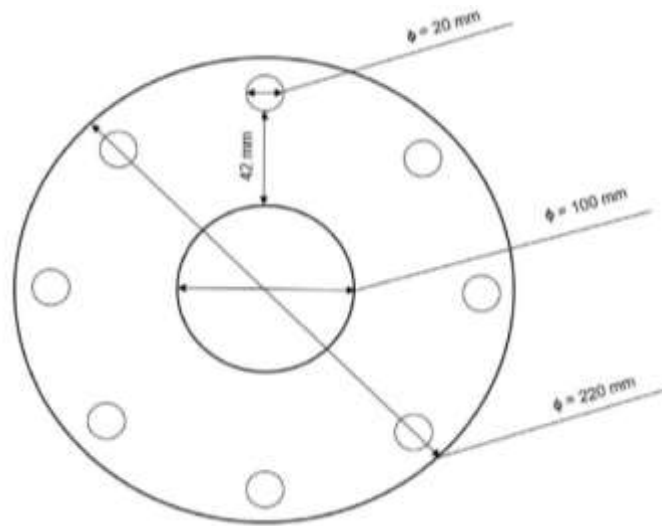

**Picture 7 – Fuel Coupling (Type A): Dimensions**

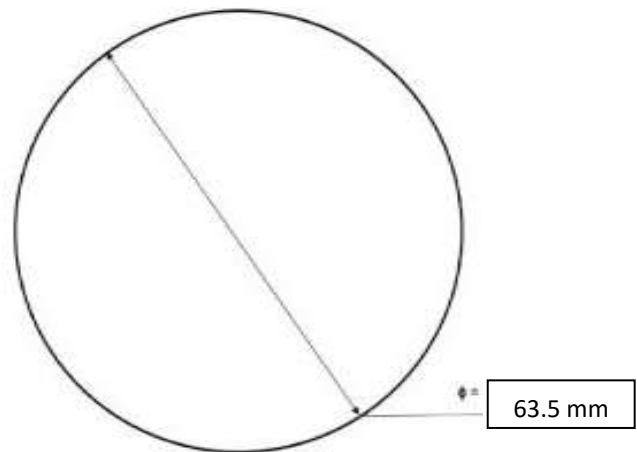

**Picture 8 – Fuel Coupling (Type B) Male End: Image and Dimensions**

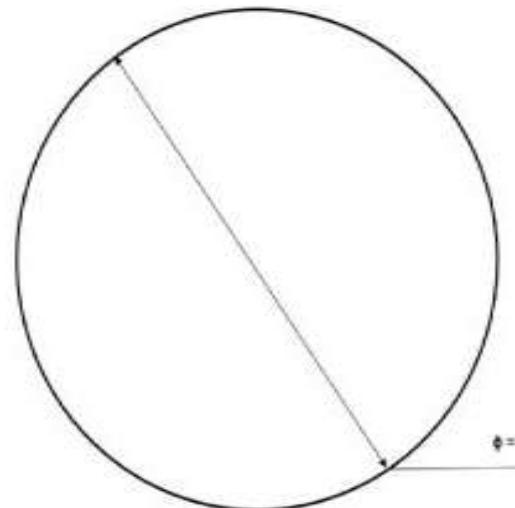

**Picture 9 – Fuel Coupling (Type C) Male End: Image and Dimensions**

76.2 mm

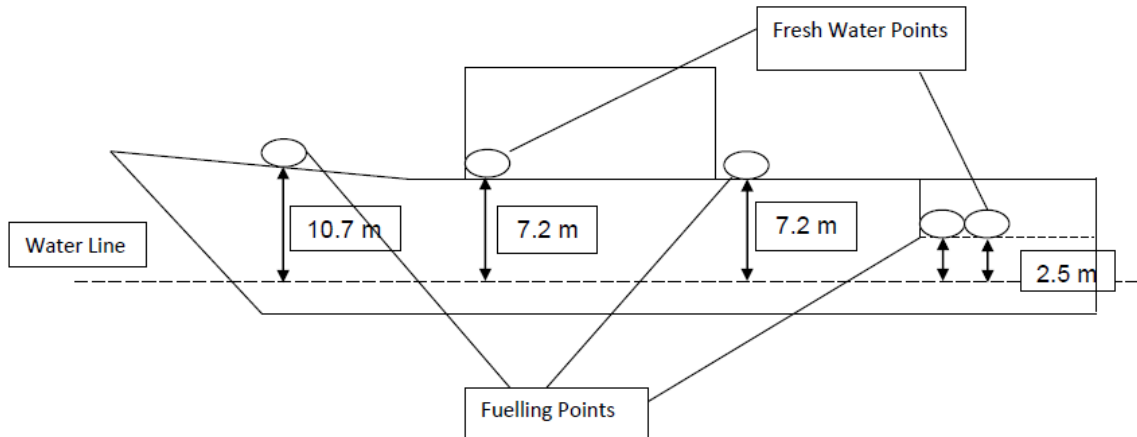

**Picture 10 – Disposition of Fueling and Fresh Water Points Onboard**



**Picture 11 – Standard Discharge Connection for Sullage**

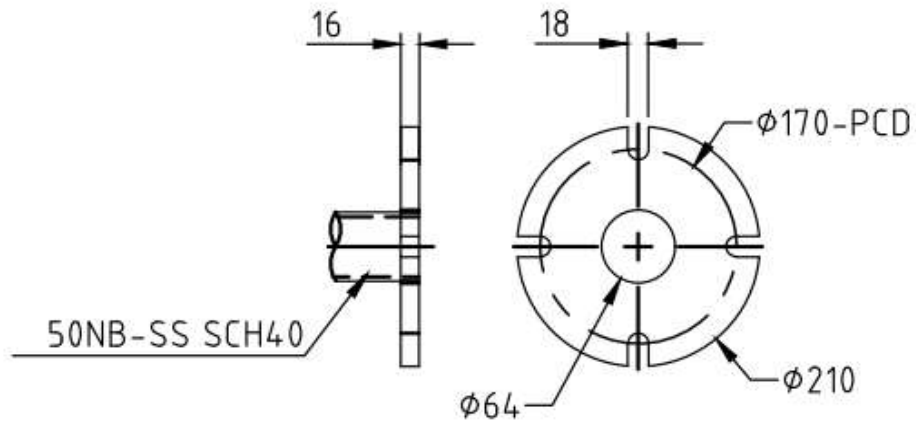

IMO INTERNATIONAL SHORE  
CONNECTION DETAIL A

**Picture 12 – Standard Discharge Connection for Sullage**